



PRO / PL SHOE REPLACEMENT & CONVERSION INSTRUCTIONS

REIMANN & GEORGER CORPORATION
HOISTING PRODUCTS
P/N 6102096

BUFFALO, NY
10/19/05

Read the following instructions thoroughly before starting work to identify which style of shoe is on track. If you don't understand a procedure, call Reimann & Georger Corporation or its distributors for assistance

PL SERIES SHOE MOUNTING BRACKET REMOVAL

1. Insure that you have all the parts and tools needed as shown below. If any parts are missing or damaged, return to place of purchase immediately. Do NOT substitute any components.

NEW KIT COMPONENTS

Quantity	Description
2	Shoe Mounting Bracket
8	10-32 X 5/8" Round Head Screw
8	10-32 Nylock Hex Nut
8	#10 SAE Flat Washer
2	Swivel Shoe Assembly
2	3/8 x 3" Hex Head Cap Screw
2	3/8 Nylock Hex Nut

TOOLS REQUIRED

Drill with 3/16" diameter bit
Hammer
Punch
File (if needed)
(2) 3/8" wrenches
(2) 1/2" wrenches
(2) 9/16" wrenches
Flat blade screwdriver

2. Using two (2) 1/2" wrenches, remove the existing safety shoe by unfastening the nut and shoulder bolt which secures the shoe to the side rail. Discard existing safety shoe, nut and shoulder bolt.
3. Using a 3/16" diameter bit, drill out four (4) pop rivets that attach two (2) mounting brackets to the side rail. Drill on the side opposite the rivet head. If necessary, use a hammer and punch to remove the rivets. Discard existing mounting brackets and rivets. Refer to Figure 1. File off any burrs that may have been made in the side rail while drilling out the rivets.
4. Repeat steps 1 through 3 for the second swivel shoe mounting bracket.

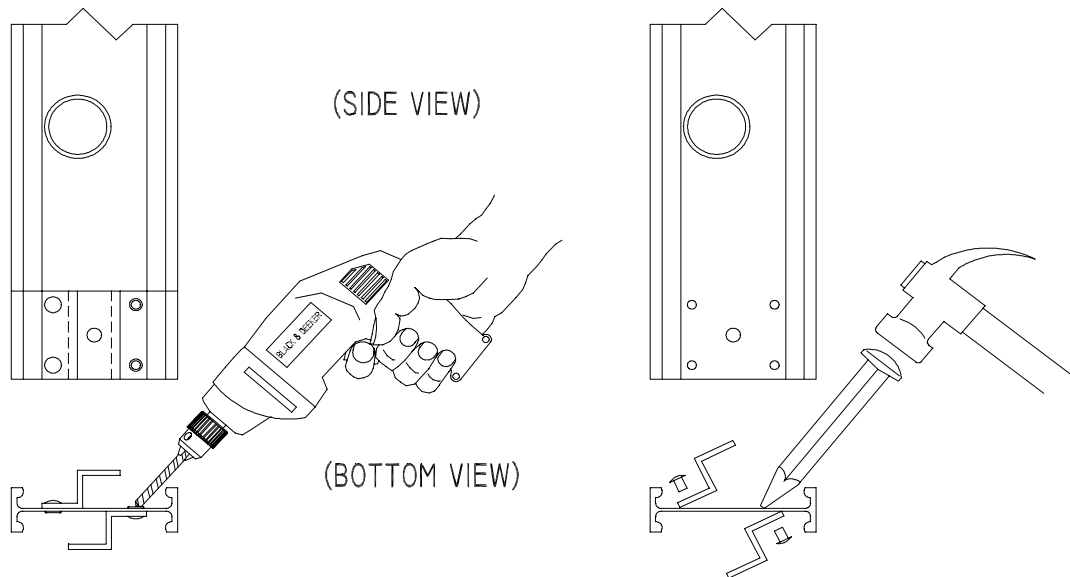

**Figure 1
(PL SERIES MOUNTING BRACKET)**

PRO SERIES SHOE MOUNTING BRACKET REMOVAL

1. Insure that you have all the parts and tools needed as shown below. If any parts are missing or damaged, return to place of purchase immediately. Do NOT substitute any components.

NEW KIT COMPONENTS

Quantity	Description
2	Shoe Mounting Bracket
8	10-32 X 5/8" Round Head Screw
8	10-32 Nylock Hex Nut
8	#10 SAE Flat Washer
2	Swivel Shoe Assembly
2	3/8 x 3" Hex Head Cap Screw
2	3/8 Nylock Hex Nut

TOOLS REQUIRED

Drill with 3/16" diameter bit
Hammer
Punch
File (if needed)
(1) 3/8" wrench
(2) 9/16" wrenches
Flat blade screwdriver

2. Using two (2) 9/16" wrenches, remove the existing swivel shoe by unfastening the nut and bolt which secures the shoe to the mounting bracket on the side rail. Discard existing swivel shoe, nut and bolt.
3. Using a 3/16" diameter bit, drill out four (4) rivets that attach mounting bracket to the side rail. Drill on the side opposite the rivet head. If necessary, use a hammer and punch to remove the rivets. Discard existing mounting brackets and rivets. Refer to Figure 2. File off any burrs that may have been made in the side rail while drilling out the rivets.
4. Repeat steps 1 through 3 for the second swivel shoe mounting bracket.

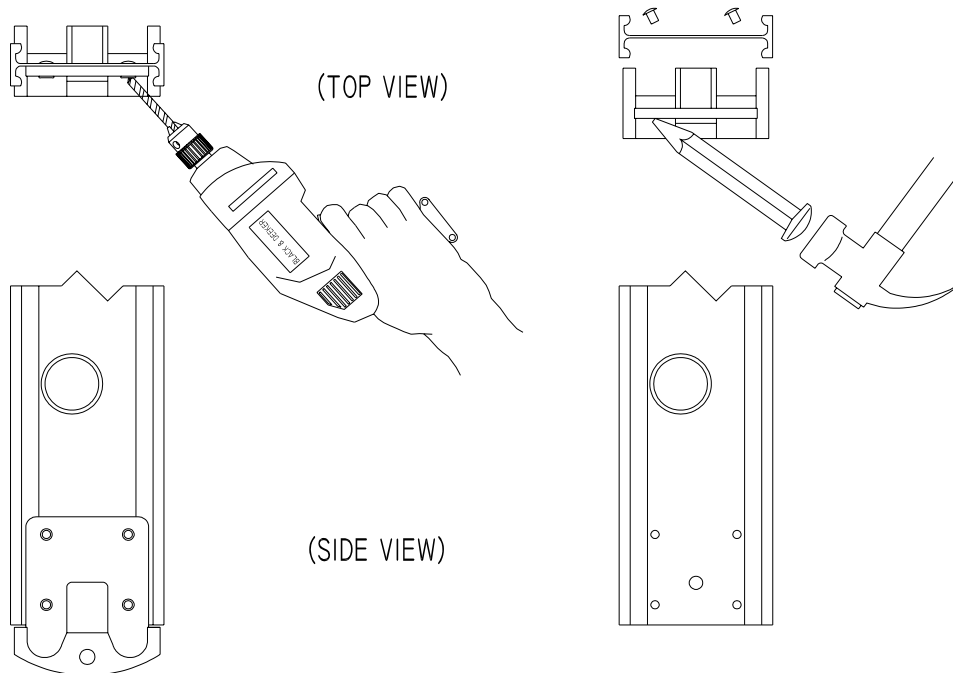

Figure 2
(PRO SERIES MOUNTING BRACKET)

CONVERTING PL SERIES TRACK TO PRO SERIES TRACK

1. Slide PRO mounting bracket fully onto inside of siderail as shown in **Figure 4**. Using bracket as a pattern, mark each siderail for hole locations. Remove bracket and drill four 3/16" holes as marked on both siderails. Continue final assembly as per instructions below.

PRO SERIES MOUNTING BRACKET AND SWIVEL SHOE ASSEMBLY

1. Position new mounting bracket on inside of the side rail as shown in Figure 3. Attach to side rail using four each #10-32 x 5/8" round head machine screws, #10 sae flat washers, and #10-32 nylock hex nuts. Tighten securely using 3/8" wrench and screw driver. All lock nuts should be on inside face of track rail.

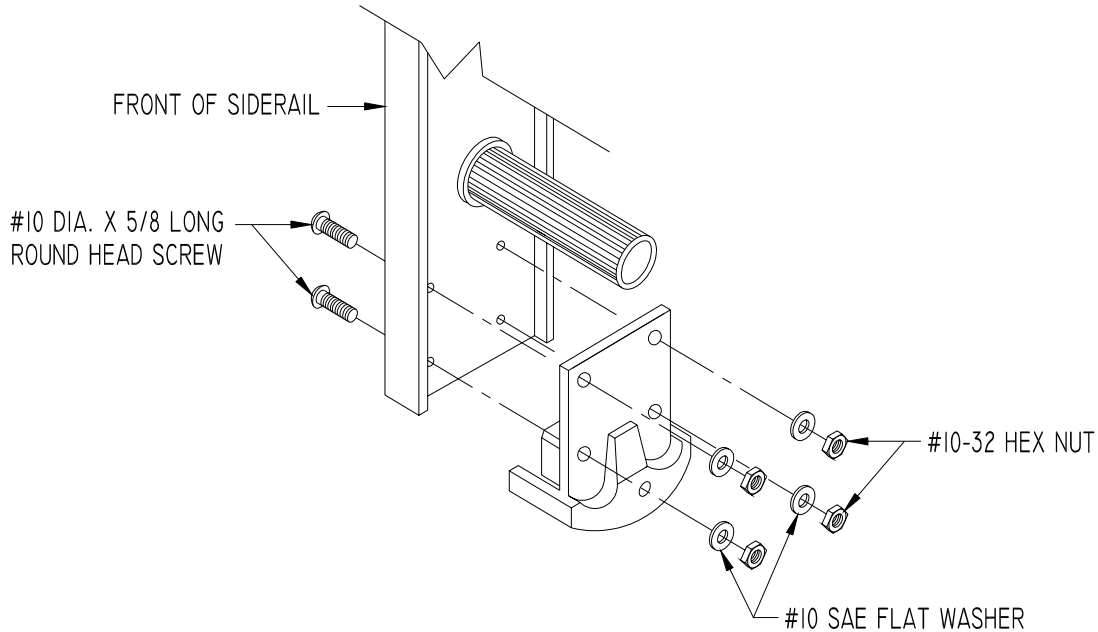

Figure 3
(PRO MOUNTING BRACKET ASSEMBLY)

2. Attach new swivel shoe to mounting bracket using one each 3/8" x 3" hex head cap screw, and 3/8" nylock hex nut. Be sure to orient spur plate correctly with respect to the side rail as shown in Figure 4. Lock nut should be on inside face of track rail. Do not over tighten, Swivel Shoe must be able to pivot freely.
3. When tightening the nut for the swivel shoe, the shoe must be free to rotate into the spur plate operating position shown in Figure 5. With the spur plate in its operating position, the rubber foot pad should face towards the user.
4. Repeat steps 1 through 3 for the second swivel shoe.

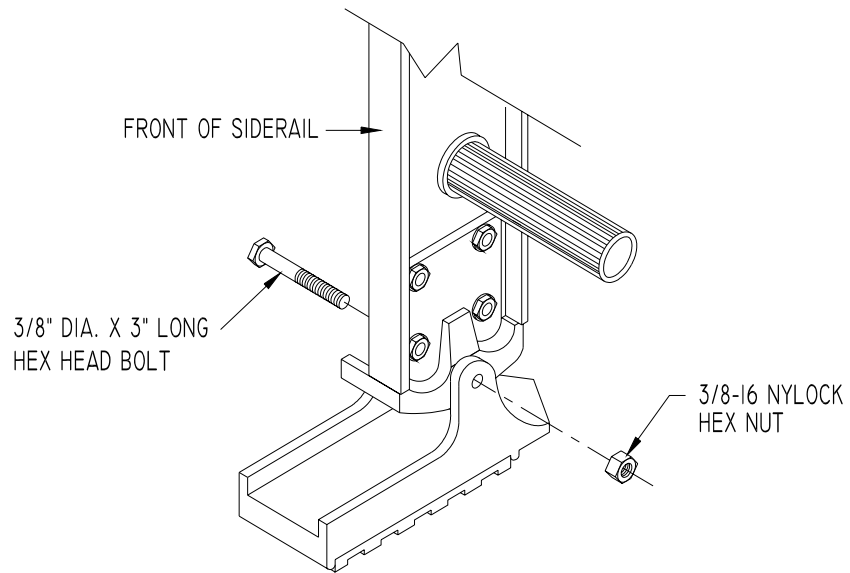

Figure 4
(PRO SWIVEL SHOE ASSEMBLY)

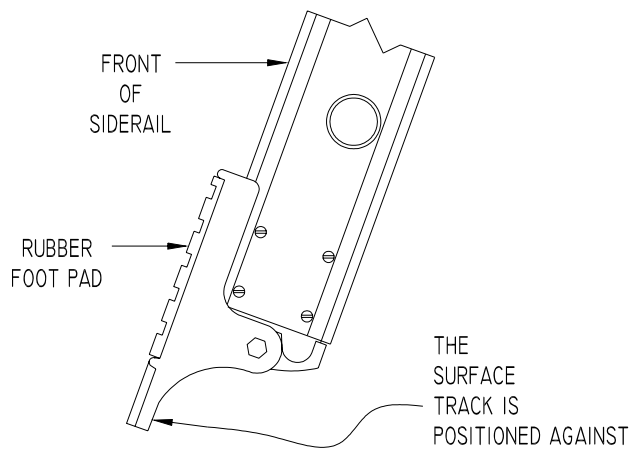

Figure 5
(SPUR PLATE OPERATING POSITION)