

# High-Performance Low-Profile Termination



## Lasting Beauty

### Well-built Aesthetics

Low profile and clean lines help enhance exterior beauty. With a heavy gauge Galvalume® and powder coated steel body, the DryerWallVent is made to last.

### Ease of Installation

Engineered for a quick, perfect fit in both retrofit and new construction, total replacement time can be as low as four minutes.

### Airflow Efficiency

The lightweight Galvalume® damper and clean opening maximize efficiency and exceed all code requirements. Less airflow restriction helps save on energy bills, and drying time.

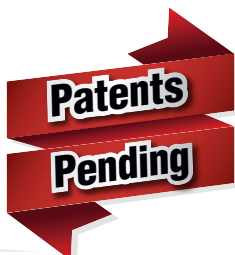

### Efficient, Low Profile Termination

- Lightweight Damper Reduces Airflow Restriction
- Integrated Magnets Deter Bird and Rodent Intrusion
- Damper Easily Accommodates Cleaning Equipment
- Gravity-Assist Damper Provides Extra Protection

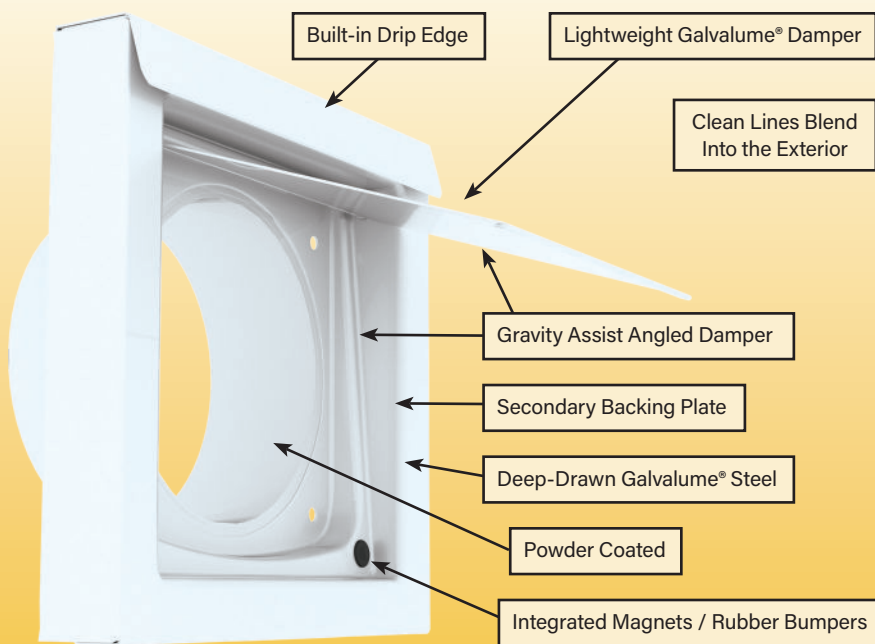

Clean Lines Blend Into the Exterior



*The Dryerbox®  
People*



**888-443-7937**

250 South Central Boulevard • Suite 207 • Jupiter FL 33458-8812 • Fax: 561-745-9723

**DryerWallVent.com**



# Technical Product Specifications

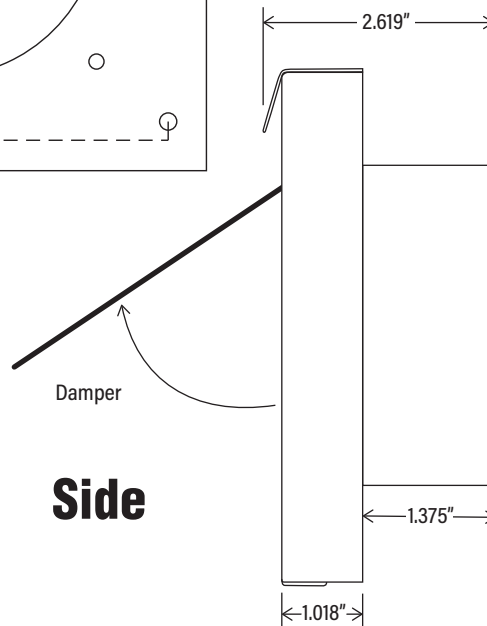
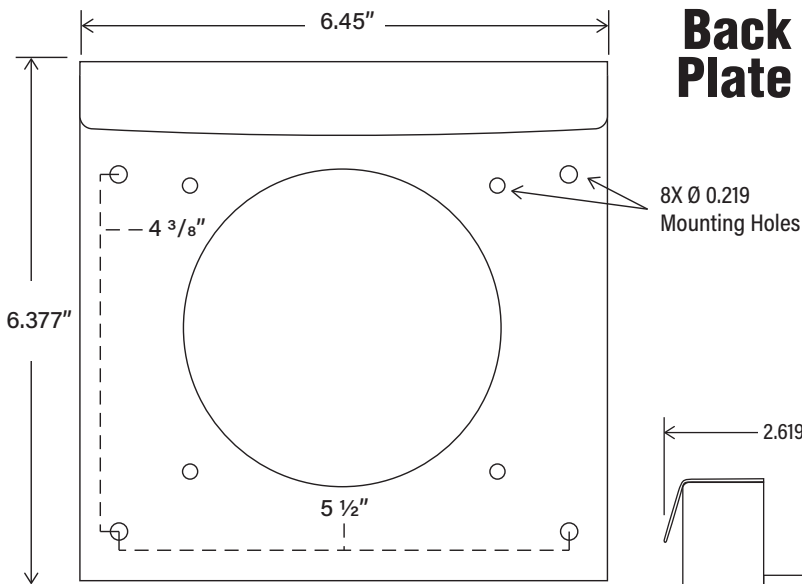
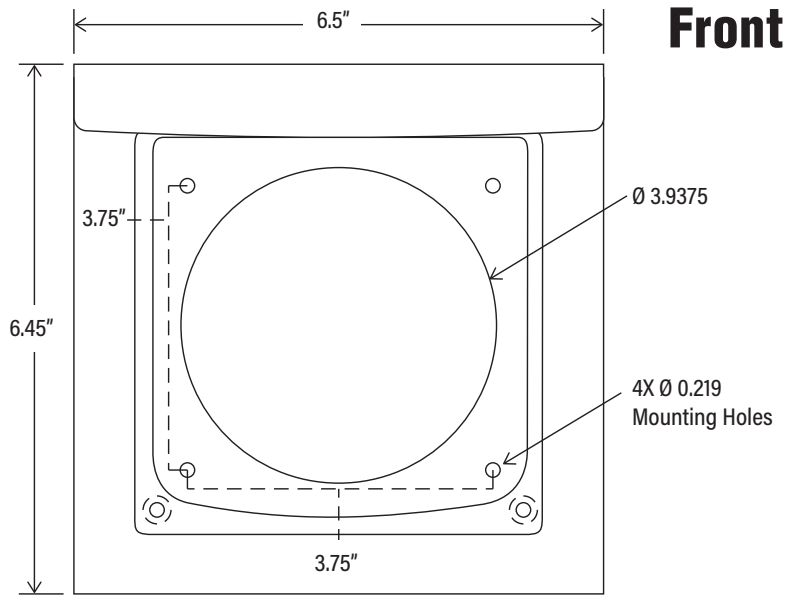

Model Number	Color
DWV4W	White
DWV4T	Tan
DWV4B	Brown
DWV4K	Black

## Performance Data

**Product Use:**

- Venting Dryer Exhaust Systems Through Exterior Walls
- Complies w/ IMC 504.4 & IRC 1502.3

**Materials:**

- Heavy Gauge Galvalume® Steel Housing
- Lightweight Gauge Galvalume® Damper
- Polyester TGIC Weather Resistant Powder Coating

## General Information

**Benefits:**

- Improves Aesthetics with Flush Installation
- Installs Easily in New and Existing Construction
- Simplifies Duct Cleaning with Easy Accessibility
- Deters Bird and Rodent Entry
- Maximizes Airflow Efficiency
- Helps Minimize Dryer Cycle Times
- Extra Protection Against the Elements

**Features:**

- Deep Drawn Manufacturing Process
- Galvalume® & Powder Coated Steel Construction
- Lightweight Damper and Heavier Frame
- Recessed Gravity Damper & Integrated Magnets
- Integrated Secondary Back Plate with Wider Mounting Holes
- Built-in Drip Edge
- Damper Opens Freely to 110°
- Low Strength Closure Magnets
- Rubber Bumpers Support Quiet Closing Damper
- Eight Built-in Mounting Holes
- **Stocked in 4 Colors: White, Tan, Brown and Black**

## Manufactured By

InOvate Technologies, Inc.  
 250 S. Central Blvd. Suite 207  
 Jupiter, FL 33458  
 Phone: (888) 443-7937  
 Fax: (561) 745-9723  
<https://dryerwallvent.com>