

TWIN SRL CARABINER

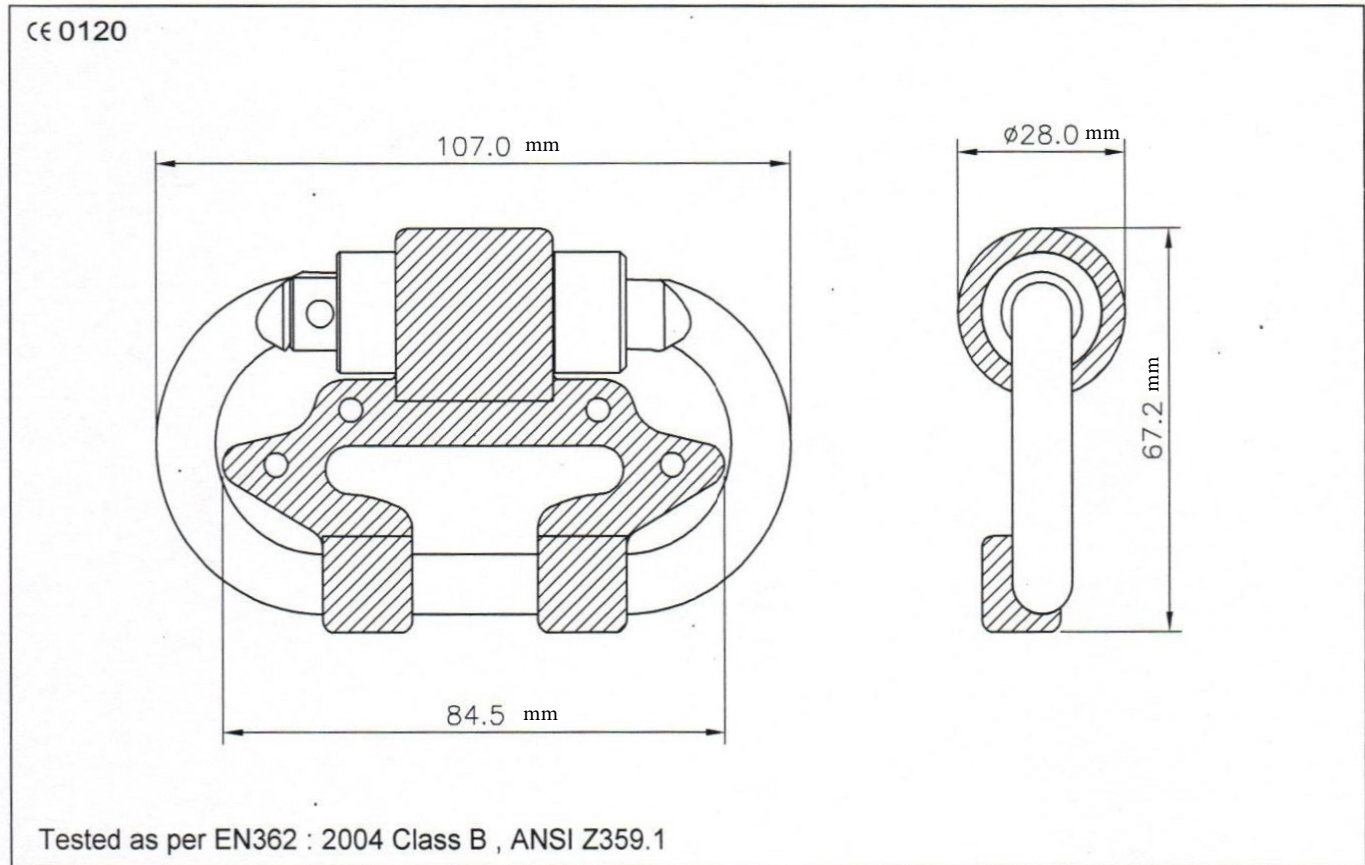

MODEL: PN169-SK



DESIGN:

- Ultimate Solution to Attach Two 6 ft. SRL's Directly with User's Harness, No Additional Connector Required.
- Reduces the Length of Swing During the Fall thereby Preventing Impact of SRL's on the Back of User's Head.

MATERIAL:

- Carabiner: Alloy Steel
- Separator: High Density Polyethylene

FINISH:

- Carabiner: Zinc Plated with Yellow / Silver Passivation

BREAKING STRENGTH:

- 5170 lbs. (Minimum)

WEIGHT:

- 0.52 lbs. \pm 0.02 lbs.

APPLICABLE STANDARDS:

- Meets or Exceeds ANSI Z359.1.